

GS1 System

Ideal-Message REMADV 4.1.0

06.04.2016

Based on EANCOM ® 2002

REMADV 4.1.0

Documentation conventions

Format and pictures

	as described in column "Format" of segment details
Character type:	a :alphabetic characters n :numeric characters an :alpha-numeric characters
Size:	Fixed : all positions must be used Variable : positions may be used up to a specified maximum
Examples:	as described in column "St" of segment details

Status indicators

	as described in column "St" of segment details
(R)equired	Indicates that the entity is required and must be sent. (This status is set by EANCOM®.)
(C)onditional	Indicates that the entity is conditional and may be sent at the discretion of the user.
(D)ependent	Indicates that the entity must be sent in certain conditions, as defined by the relevant explanatory note.
(N)ot used	Indicates that the entity is not used.

Restriction indicators

	as described in column "R" of segment details
Restricted (*)	A data element marked with an asterisk (*) in the fourth column of the segment details of a message indicates that the listed codes in column five are the only codes available for use with the data element at the same level as the asterisk, in the current segment, in the current message.
Open	All data elements in which coded representation of data is possible, and in which a restricted set of code values is not indicated, are open. The available codes are listed in the Data Elements and Code Sets Directory (Part III of this manual). Code values may be given as examples or there may be a note on the format or type of code to be used.

REMADV 4.1.0

Message description

The remittance advice announces a payment transaction.
The amounts to be paid of the whole remittance advice, each document and each line of the documents, must all be in the same currency as the payment currency
Each remittance advice refers to only one settlement date.

REMADV 4.1.0

Branching diagram

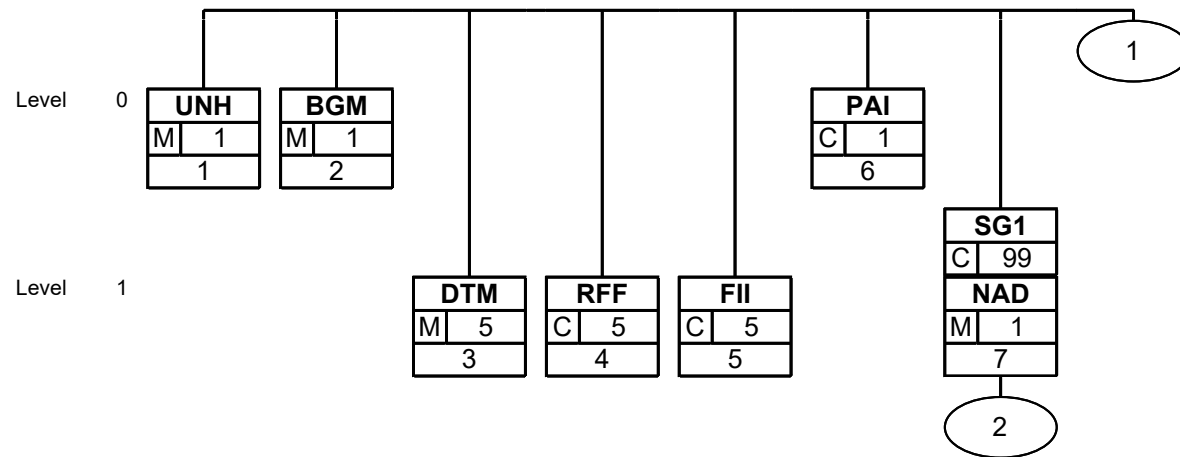

REMADV 4.1.0

Branching diagram

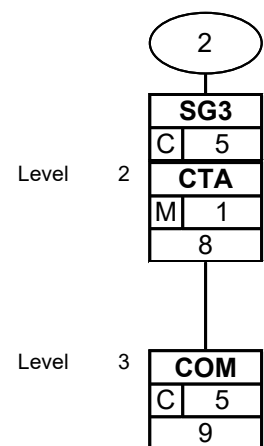

REMADV 4.1.0

Branching diagram

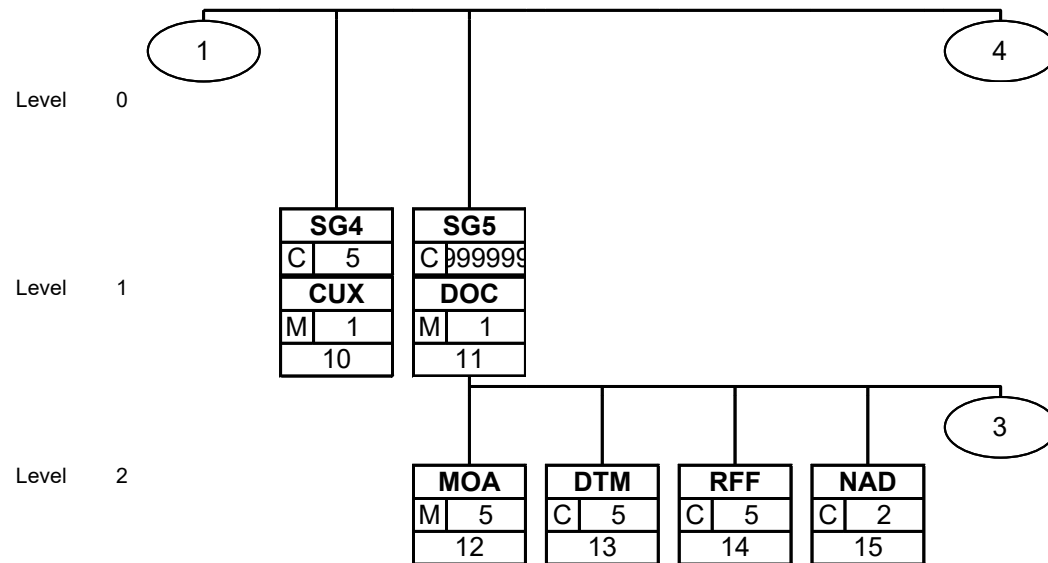

REMADV 4.1.0

Branching diagram

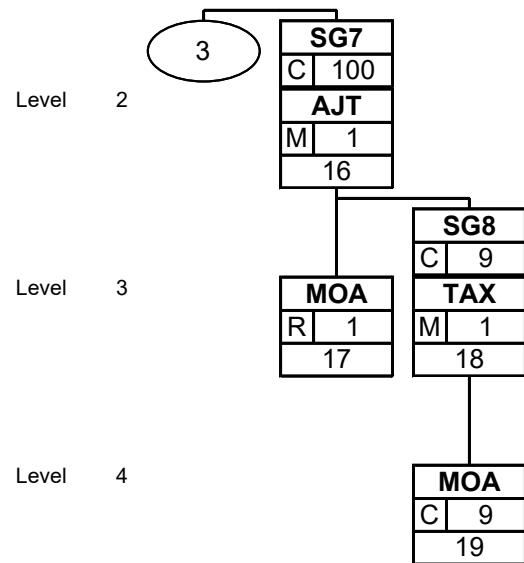

REMADV 4.1.0

Branching diagram

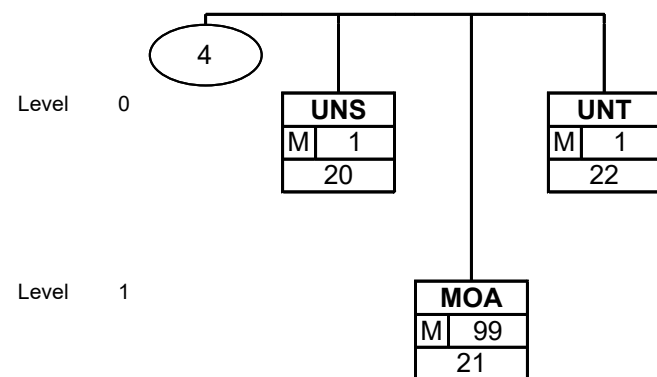

REMADV 4.1.0

Segments Layout

Segment **UNH** No.: 1 Level: 0 Message header
 Status: M Max. occ.: 1

Description Message header

Description of Segment:

	Description	St Format	*	Example	Remarks
0062	Message reference number	M an..14		+124551	Senders unique message reference. Sequence number of the messages in the interchange. DE 0062 in the UNT will be exactly the same. Sender generated. Numerically ascending order without gaps, starting with 1
S009	Message identifier	M			
0065	Message type	M an..6	*	+REMA DV	REMAD = Remittance advice message V
0052	Message version number	M an..3	*	:D	D = Draft version/UN/EDIFACT Directory
0054	Message release number	M an..3	*	:01B	01B = Release 2001 - B
0051	Controlling agency	M an..2	*	:UN	UN = UN/CEFACT
0057	Association assigned code	R an..6	*	: EAN005'	EAN00 = EAN version control number 5 (EAN Code)

Description:

This segment is used to head, identify and specify a message.

DE's 0065, 0052, 0054, and 0051: Indicate that the message is a UNSM Remittance Advice based on the D.01B directory under the control of the United Nations.

Example:

UNH+124551+REMADV:D:01B:UN:EAN005'

REMADV 4.1.0

Segments Layout

Segment **BGM** No.: 2 Level: 0 Beginning of message
 Status: M Max. occ.: 1

Description Beginning of message

Description of Segment:

	Description	St Format	*	Example	Remarks
C002	Document/message name	R			
1001	Document name code	R an..3	*	+481	481 = Remittance advice
C106	Document/message identification	R			
1004	Document identifier	R an..35		+123553	Remittance Advice number assigned by the document initiator.
1225	Message function code	R an..3	*	+9'	9 = Original 31 = Copy

Description:

This segment is used to indicate the type and function of a message and to transmit its identifying number. All references other than the document number DE 1004 are in the RFF segment.

Example:

BGM+481+123553+9'

REMADV 4.1.0

Segments Layout

Segment **DTM** No.: 3 Level: 1 Date/time/period
 Status: M Max. occ.: 5

Description Date/time/period

Description of Segment:

	Description	St Format	*	Example	Remarks
C507	Date/time/period	M			
2005	Date or time or period function code qualifier	M an..3	*	+138	137 = Document/message date/time 138 = Payment date 203 = Execution date/time, requested Qualifier 137 must always be transmitted
2380	Date or time or period value	R an..35		: 2006012 6000000	
2379	Date or time or period format code	R an..3	*	:204'	204 = CCYYMMDDHHMMSS

Description:

This segment is used to specify dates related to the complete remittance advice message.
 DE 2005: Identification of the 'Document/message date/time' (code value 137) is mandatory in an EANCOM message.

Example:

DTM+138:20060126000000:204'

REMADV 4.1.0

Segments Layout

Segment **RFF** No.: 4 Level: 1 Reference
 Status: C Max. occ.: 5

Description Reference

Description of Segment:

	Description	St Format	*	Example	Remarks
C506	Reference	M			
1153	Reference code qualifier	M an..3	*	+AEK	AEK = Payment order number
1154	Reference identifier	R an..70		:34556'	RA = Remittance advice number

Description:

This segment is used to specify any references which relate to the complete remittance advice. References only applying to the complete Remittance Advice should be given at this point. References to a specific commercial document/message, e.g., Invoice, Purchase Order or Despatch Advice are provided in the RFF segment of the detail section per document/message identified in the DOC segment.

Example:

RFF+AEK:34556'

REMADV 4.1.0

Segments Layout

Segment **FII** No.: 5 Level: 1 Financial institution information
 Status: C Max. occ.: 5

Description Financial institution information

Description of Segment:

	Description	St Format	*	Example	Remarks
3035	Party function code qualifier	M an..3	*	+RB	RB = Receiving financial institution
C078	Account holder identification	R			
3194	Account holder identifier	R an..35		+13577/ 56-33	
3192	Account holder name	O an..35		: Lieferant GmbH	
3192	Account holder name	O an..35		:Oberwil	
C088	Institution identification	O			
3433	Institution name code	O an..11		+BLKBC H22	
1131	Code list identification code	O an..17	*	:25	25 = Bank identification
3055	Code list responsible agency code	D an..3	*	:17'	5 = ISO 17 = S.W.I.F.T.

Description:

This segment is used to identify financial institution information related to the parties involved in the Remittance Advice.

Example:

FII+RB+13577/56-33:Lebensmittel AG:Wil+BLKBCH22:25:17'

REMADV 4.1.0

Segments Layout

Segment **PAI** No.: 6 Level: 0 Payment instructions
 Status: C Max. occ.: 1

Description Payment instructions

Description of Segment:

	Description	St Format	*	Example	Remarks
C534	Payment instruction details	M			
4439	Payment conditions code	O an..3	*	+1	1 = Direct payment
4431	Payment guarantee means code	C an..3	:	:	
4461	Payment means code	O an..3	*	:42'	20 = Cheque 30 = Credit transfer 31 = Debit transfer 42 = Payment to bank account

Description:

This segment is used by the sender of the Remittance Advice to indicate how payment is being made.

Example:

PAI+1::42'

REMADV 4.1.0

Segments Layout

Group	SG1	Status:C	Max. occ.: 99	NAD-SG3
Segment	NAD	No.: 7 Status:M	Level: 1 Max. occ.: 1	Name and address

Description Name and address

Description of Segment:

	Description	St Format	*	Example	Remarks
3035	Party function code qualifier	M an..3	*	+SU	BY = Buyer PE = Payee PR = Payer SU = Supplier
C082	Party identification details	A			
3039	Party identifier	M an..35		+761234 5000190	
1131	Code list identification code	N an..17		:	
3055	Code list responsible agency code	R an..3	*	:9	9 = EAN (International Article Numbering association)
C058	Name and address	N			
3124	Name and address description	M an..35		+	
C080	Party name	N			
3036	Party name	M an..35		+	
C059	Street	N			
3042	Street and number or post office box identifier	M an..35		+	
3164	City name	N an..35		+	
C819	Country sub-entity details	C			
3229	Country sub-entity name code	C an..9		+	
3251	Postal identification code	N an..17		+	
3207	Country name code	C an..3		+CH'	ISO 3166 two alpha code

Description:

This segment is used to identify the parties exchanging the Remittance Advice message, and if necessary, any associated parties. The identification of the payer and payee, and buyer and seller if different from the payer and payee, are mandatory in the Remittance Advice message.

Example:

NAD+SU+7612345000190::9'

REMADV 4.1.0

Segments Layout

Group	SG1	Status:C	Max. occ.: 99	NAD-SG3
Group	SG3	Status:C	Max. occ.: 5	CTA-COM
Segment	CTA	No.: 8 Status:M	Level: 2 Max. occ.: 1	Contact information

Description Contact information

Description of Segment:

	Description	St Format	*	Example	Remarks
3139	Contact function code	R an..3	*	+AD	AD = Accounting contact
C056	Department or employee details	O			
3413	Department or employee name code	O an..17		+hm	
3412	Department or employee name	O an..35		:Hans Müller'	

Description:

This segment is used to identify contact names or departments within the party specified in the NAD segment.

Contact information only with NAD-Qualifier PR

Example:

CTA+AD+hm:Hans Müller'

REMADV 4.1.0

Segments Layout

Group	SG1	Status:C	Max. occ.: 99	NAD-SG3
Group	SG3	Status:C	Max. occ.: 5	CTA-COM
Segment	COM	No.: 9 Status:C	Level: 3 Max. occ.: 5	Communication contact

Description Communication contact

Description of Segment:

	Description	St Format	*	Example	Remarks
C076	Communication contact	M			
3148	Communication address identifier	M an..51		+055 877 12 85	
3155	Communication address code qualifier	M an..3	*	:TE'	EM = Electronic mail FX = Fax TE = Telephone

Description:

This segment identifies the communications number, and type of communications, for the person and/or department identified in the preceding CTA segment.
Contact information only with NAD-Qualifier PR

Example:

COM+055 877 12 85:TE'

REMADV 4.1.0

Segments Layout

Group	SG4	Status:C	Max. occ.: 5	CUX
Segment	CUX	No.: 10 Status:M	Level: 1 Max. occ.: 1	Currencies

Description Currencies

Description of Segment:

	Description	St Format	*	Example	Remarks
C504	Currency details	R			
6347	Currency usage code qualifier	M an..3	*	+2	2 = Reference currency
6345	Currency identification code	R an..3		:CHF	ISO 4217 three alpha code
6343	Currency type code qualifier	R an..3	*	:11'	11 = Payment currency

Description:

This segment is used to indicate currency information related to the complete remittance advice. The CUX segment may be omitted for national exchanges. The CUX segment is mandatory for international exchanges.

A remittance advice will refer to ONLY ONE payment currency.

The CUX segment may be used also to indicate other currencies specified previously in the transaction, such as pricing currency, invoicing currency, etc.

When specifying Reference and Target Currencies for international trade, one occurrence of CUX is all that is required. The reference currency is identified in the first occurrence of composite C504, with the target currency specified in the second occurrence of C504, The rate of exchange between the two is detailed in DE 5402.

The general rule for calculating rate of exchange is as follows:

Reference Currency multiplied by Rate = Target Currency.

Example:

CUX+2:CHF:11'

REMADV 4.1.0

Segments Layout

Group **SG5** Status:C Max. occ.: 999999 DOC-MOA-DTM-RFF-NAD-SG7

Segment **DOC** No.: 11 Level: 1 Document/message details
 Status:M Max. occ.: 1

Description Document/message details

Description of Segment:

	Description	St Format	*	Example	Remarks
C002	Document/message name	M			
1001	Document name code	D an..3	*	+380	83 = Credit note rel. to financial adjustments 84 = Debit note rel. to financial adjustments 262 = Consolidated credit note - goods and services 380 = Commercial invoice 381 = Credit note - goods and services 383 = Debit note - goods and services 385 = Consolidated invoice
1131	Code list identification code	N an..17	:		
3055	Code list responsible agency code	N an..3	:		
1000	Document name	O an..35	:	:X	
C503	Document/message details	R			
1004	Document identifier	R an..35		+20061001'	

Description:

This segment is used to provide details of the documents, e.g., a group of invoices, to which the Remittance Advice refers. The detail section of the Remittance Advice is formed by a repeating groups of DOC segments. Individual document line item information is provided in the DLI segment. Invoices and credit notes can be transmitted mixed, per REMADV

Example:

DOC+380+20061001'

REMADV 4.1.0

Segments Layout

Group **SG5** Status:C Max. occ.: 999999 DOC-MOA-DTM-RFF-NAD-SG7

Segment **MOA** No.: 12 Level: 2 Monetary amount
 Status:M Max. occ.: 5

Description Monetary amount

Description of Segment:

	Description	St Format	*	Example	Remarks
C516	Monetary amount	M			
5025	Monetary amount type code qualifier	M an..3	*	+12	9 = Amount due/amount payable 12 = Amount remitted 39 = Invoice total amount 52 = Discount amount 77 = Invoice amount 109 = Payment discount amount 124 = Tax amount 125 = Taxable amount 265 = Commission amount
5004	Monetary amount	R n..35		:1500'	

Description:

This segment is used to provide monetary amounts related to the document specified in the previous DOC segment.

The specification of the amount due and amount remitted relevant to the particular document identified in the DOC segment is mandatory.

Example:

MOA+12:1500'

REMADV 4.1.0

Segments Layout

Group **SG5** Status:C Max. occ.: 999999 DOC-MOA-DTM-RFF-NAD-SG7

Segment **DTM** No.: 13 Level: 2 Date/time/period
 Status:C Max. occ.: 5

Description Date/time/period

Description of Segment:

	Description	St Format	*	Example	Remarks
C507	Date/time/period	M			
2005	Date or time or period function code qualifier	M an..3	*	+15	15 = Promotion start date/time 137 = Document/message date/time 140 = Payment due date 179 = Booking date/time 265 = Due date 321 = Promotion date/period Existing qualifiers 140, 179 + 265 are approved by GS1 WR 16-000104. Those qualifiers will be adapted in EANCOM Release 2016
2380	Date or time or period value	R an..35		: 2006031 5100000	
2379	Date or time or period format code	R an..3	*	:204'	204 = CCYYMMDDHHMMSS 610 = CCYYMM 616 = CCYYWW

Description:

This segment is used to indicate the date of the document identified in the DOC segment.

Example:

DTM+15:20060315100000:204'

REMADV 4.1.0

Segments Layout

Group **SG5** Status:C Max. occ.: 999999 DOC-MOA-DTM-RFF-NAD-SG7

Segment **RFF** No.: 14 Level: 2 Reference
 Status:C Max. occ.: 5

Description Reference

Description of Segment:

	Description	St Format	*	Example	Remarks
C506	Reference	M			
1153	Reference code qualifier	M an..3	*	+PQ	ACE = Related document number AHM = Debtor's reference number DM = Document number PQ = Payment reference The code AHM is used to transmit the archive no.
1154	Reference identifier	R an..70		: 1130000 8858691 0051486 360007'	

Description:

This segment is used to provide references related to the document identified in the DOC segment.

Example:

RFF+PQ:113000088586910051486360007'

REMADV 4.1.0

Segments Layout

Group **SG5** Status:C Max. occ.: 999999 DOC-MOA-DTM-RFF-NAD-SG7

Segment **NAD** No.: 15 Level: 2 Name and address
 Status:C Max. occ.: 2

Description Name and address

Description of Segment:

	Description	St Format	*	Example	Remarks
3035	Party function code qualifier	M an..3	*	+BY	BY = Buyer DP = Delivery party PE = Payee SU = Supplier Existing qualifier PE is approved by GS1 WR 16-000104. This qualifier will be adapted in EANCOM Release 2016
C082	Party identification details	R			
3039	Party identifier	M an..35		+761234 5000183	
1131	Code list identification code	N an..17		:	
3055	Code list responsible agency code	R an..3	*	:9'	9 = EAN (International Article Numbering association)

Description:

This segment is used to identify the buyer or delivery party when different to the buyer, for the current document.

Example:

NAD+BY+7612345000183::9'

REMADV 4.1.0

Segments Layout

<i>Group</i>	SG5	Status:C	Max. occ.: 999999	DOC-MOA-DTM-RFF-NAD-SG7
<i>Group</i>	SG7	Status:C	Max. occ.: 100	AJT-MOA-SG8
<i>Segment</i>	AJT	No.: 16 Status:M	Level: 2 Max. occ.: 1	Adjustment details

Description Adjustment details

Description of Segment:

	Description	St Format	*	Example	Remarks
4465	Adjustment reason description code	M an..3	*	+66'	19 = Trade discount 38 = Deducted bonus 66 = Cash discount 67 = Delcredere costs 68 = Early payment allowance adjustment 90 = Treasury management service charge

Description:

This segment is used to indicate the reason for an adjustment to the current document.

Adjustments can be given for the referenced document identified in the DOC segment and additionally, can be given per line item in the AJT segment in the following DLI segment group.

DE 1082: If specific references or information to a line item number in a document are required, then the line item number is given in the DLI segment and the adjustment given in the AJT segment, both in segment group 10.

Example:

AJT+66'

REMADV 4.1.0

Segments Layout

Group	SG5	Status:C	Max. occ.: 999999	DOC-MOA-DTM-RFF-NAD-SG7
Group	SG7	Status:C	Max. occ.: 100	AJT-MOA-SG8
Segment	MOA	No.: 17 Status:R	Level: 3 Max. occ.: 1	Monetary amount

Description Monetary amount

Description of Segment:

	Description	St Format	*	Example	Remarks
C516	Monetary amount	M			
5025	Monetary amount type code qualifier	M an..3	*	+165	5 = Adjusted amount 165 = Adjustment amount 265 = Commission amount Existing qualifier 265 is approved by GS1 WR 16-000104. This qualifier will be adapted in EANCOM Release 2016
5004	Monetary amount	R n..35		:3'	

Description:

This segment is used to indicate the value of the adjustment amount.

Adjustment amounts can be given for information purposes only, i.e., not for calculation. The adjustment amount will not necessarily equal the difference between the amount due and the amount remitted.

The adjustment amount will always be expressed in terms of the remittance/payment currency.

Please note that negative adjustment must be explicitly indicated by the minus (-) sign.

Example:

MOA+165:3'

REMADV 4.1.0

Segments Layout

Group	SG5	Status:C	Max. occ.: 999999	DOC-MOA-DTM-RFF-NAD-SG7
Group	SG7	Status:C	Max. occ.: 100	AJT-MOA-SG8
Group	SG8	Status:C	Max. occ.: 9	TAX-MOA
Segment	TAX	No.: 18 Status:M	Level: 3 Max. occ.: 1	Duty/tax/fee details

Description Duty/tax/fee details

Description of Segment:

	Description	St Format	*	Example	Remarks
5283	Duty or tax or fee function code qualifier	M an..3	*	+7	7 = Tax
C241	Duty/tax/fee type	C			
5153	Duty or tax or fee type name code	C an..3		+	
C533	Duty/tax/fee account detail	C			
5289	Duty or tax or fee account code	M an..6		+	
5286	Duty or tax or fee assessment basis value	C an..15		+	
C243	Duty/tax/fee detail	R			
5279	Duty or tax or fee rate code	C an..7		+	
1131	Code list identification code	C an..17		:	
3055	Code list responsible agency code	C an..3		:	
5278	Duty or tax or fee rate	R an..17		:7.6	The actual rate of tax/duty.
5305	Duty or tax or fee category code	C an..3	*	+A'	S = Standard rate AE = VAT Reverse charge O = Services outside scope of tax

Description:

This segment is used to signify whether the processing adjustments are subject to tax.

Dependency Notes:

DE C241 and 5305: Tax types and categories will differ from country to country. They are to be defined by national guidelines.

Example:

TAX+7++++:::7.6'

REMADV 4.1.0

Segments Layout

Group	SG5	Status:C	Max. occ.: 999999	DOC-MOA-DTM-RFF-NAD-SG7
Group	SG7	Status:C	Max. occ.: 100	AJT-MOA-SG8
Group	SG8	Status:C	Max. occ.: 9	TAX-MOA
Segment	MOA	No.: 19 Status:C	Level: 4 Max. occ.: 9	Monetary amount

Description Monetary amount

Description of Segment:

	Description	St Format	*	Example	Remarks
C516	Monetary amount	M			
5025	Monetary amount type code qualifier	M an..3	*	+124	124 = Tax amount 125 = Taxable amount 178 = Exact amount
5004	Monetary amount	R n..35		:2.38'	

Description:

This segment is used to specify in monetary terms the amount of tax due on the current document.

Example:

MOA+124:2.38'

REMADV 4.1.0

Segments Layout

Segment **UNS** No.: 20 Level: 0 Section control
 Status:M Max. occ.: 1

Description Section control

Description of Segment:

	Description	St Format	*	Example	Remarks
0081	Section identification	M a1	*	+S'	S = Detail/summary section separation

Description:

This segment is used to separate the detail and summary sections of the Remittance Advice message.

Example:

UNS+S'

REMADV 4.1.0

Segments Layout

Segment **MOA** No.: 21 Level: 1 Monetary amount
 Status: M Max. occ.: 99

Description Monetary amount

Description of Segment:

	Description	St Format	*	Example	Remarks
C516	Monetary amount	M			
5025	Monetary amount type code qualifier	M an..3	*	+12	12 = Amount remitted 39 = Invoice total amount 77 = Invoice amount 124 = Tax amount 125 = Taxable amount 138 = Total monetary discount amount 165 = Adjustment amount 265 = Commission amount Existing qualifiers 77, 124, 125 + 265 are approved by GS1 WR 16-000104. Those qualifiers will be adapted in EANCOM Release 2016 The qualifier 12 is mandatory. If the payment amount and the billing amount is not the same, the following qualifier should be transmitted as well, qualifier 39 and optionally 138 or 165.
5004	Monetary amount	R n..35		:1500'	

Description:

This segment is used to indicate the total amount being remitted in this remittance advice.

The currency information for the remitted amount will already have been provided in the CUX segment at heading level.

Example:

MOA+12:1500'

REMADV 4.1.0

Segments Layout

Segment **UNT** No.: 22 Level: 0 Message trailer
 Status: M Max. occ.: 1

Description Message trailer

Description of Segment:

	Description	St Format	*	Example	Remarks
0074	Number of segments in the message	M n..6		+22	The total number of segments in the message is detailed in here.
0062	Message reference number	M an..14		+124551'	The message reference numbered detailed here should equal the one specified in the UNH segment.

Description:

This segment is a mandatory UN/EDIFACT segment. It must always be the last segment in the message.

Example:

UNT+22+124551'

REMADV 4.1.0

Example

Message included mandatory information only:

```
UNH+1+ORDERS:D:01B:UN:EAN010'  
BGM+220+120001+9'  
DTM+137:20061205000000:204'  
RFF+ON:652744'  
NAD+BY+7612345000015::9'  
NAD+SU+7612346000014::9'  
LIN+1++7612346000107:SRV'  
QTY+21:12'  
UNS+S'  
CNT+2:1'  
UNT+11+1'
```

REMADV 4.1.0

List of changes

No.	Description	Segments and elements			
01	24.03.2006/3.0.0: Publication Version 3.0.0	1	UNH		
02	06.04.2016/4.1.0: Publication versioin 4.1.0 (CR 15-007)	1	UNH		
03	06.04.2016/4.1.0: Country code added (CR 15-007)	7	NAD		3207
			SG1#1		
04	06.12.2010/3.2.0: Qualifiers 83/84/262/383/385 added (CR 10-005)	11	DOC	C002	1001
			SG5#1		
05	06.12.2010/3.2.0: Field 1000 allowed to be 'Conditional' (CR 10-005)	11	DOC	C002	1000
			SG5#1		
06	06.04.2016/4.1.0: Qualifiers 77, 124 + 125 added (CR 15-007)	12	MOA	C516	5025
			SG5#1		
07	06.04.2016/4.1.0: Qualifiers 140, 179 + 265 added (CR 15-007)	13	DTM	C507	2005
			SG5#1		
08	06.04.2016/4.1.0: Qualifiers 610 + 616 added (CR 15-007)	13	DTM	C507	2379
			SG5#1		
09	23.01.2008/3.1.0: Qualifier AHM added (CR 07-009)	14	RFF	C506	1153
			SG5#1		
10	06.04.2016/4.1.0:Country code added (CR 15-007)	14	RFF	C506	1153
			SG5#1		
11	06.04.2016/4.1.0: Qualifier PE added (CR 15-007)	15	NAD		3035
			SG5#1		
12	06.04.2016/4.1.0: Qualifiers 19, 38, 67, 68 added (CR 15-007)	16	AJT		4465
			SG5#1\SG7#1		
13	06.04.2016/4.1.0: Qualifier 42E replaced by qualifier 90 (CR 15-007)	16	AJT		4465
			SG5#1\SG7#1		
14	06.04.2016/4.1.0: Qualifier 265 (CR 15-007)	17	MOA	C516	5025
			SG5#1\SG7#1		
15	06.04.2016/4.1.0: Qualifiers S, AE + O added (CR 15-007)	18	TAX		5305
			SG5#1\SG7#1\SG8#1		
16	06.04.2016/4.1.0: Qualifier 178 added (CR 15-007)	19	MOA	C516	5025
			SG5#1\SG7#1\SG8#1		
17	06.04.2016/4.1.0: Qualifiers 77, 124, 125 + 265 added (CR 15-007)	21	MOA	C516	5025

GS1 Schweiz ist
der Fachverband
für nachhaltige
Wertschöpfungs-
netzwerke.

GS1 Switzerland
Monbijoustrasse 68
3007 Bern

T +41 58 800 70 00
www.gs1.ch



Kompetenzplattform Netzwerke aufbauen – Erfahrungen austauschen



Kompetenzvermittlung Wissen vermitteln – Kompetenz steigern



Kollaboration Zusammenarbeit fördern – Wertschöpfung verbessern



Standards Standards nutzen – Effizienz erhöhen



Nachhaltigkeit Ganzheitlich denken – Ressourcen schonen